



COLE'S 1830 SERIES IS IDEAL FOR CRITICAL AND DEMANDING APPLICATIONS THAT REQUIRE THE HIGHEST POSSIBLE RELIABILITY REQUIREMENTS. CONSTRUCTED WITH QUALITY MATERIALS IN A POSITIVE-AIR-PRESSURE ROOM ENVIRONMENT, THIS PRECISION SWITCH IS PERFECT FOR USAGE IN AIRCRAFT, MEDICAL EQUIPMENT, ELECTRONICS, ORDNANCE, AND INSTRUMENTATION.



The 1830 Series meets or exceeds applicable requirements of MIL-DTL-3786 Style SR35.

Certified test reports available on request.

The Innovative Switch Company

The ultimate in a 30 degree rotation, single deck rotary switch, the Cole 1830 Series offers precision and unique circuit versatility in a .562 inch diameter, fully enclosed package. It has been engineered to meet or exceed applicable MIL-DTL-3786, Style SR35 requirements and has been tested per MIL-STD-202 as follows:

- THERMAL SHOCK PER MIL-STD-202; METHOD 107, TEST CONDITION "B"
- VIBRATION PER MIL-STD-202; METHOD 204, TEST CONDITION "B"
- MEDIUM SHOCK PER MIL-STD-202; METHOD 213
- HIGH SHOCK PER MIL-STD-202; METHOD 207
- MOISTURE RESISTANCE PER MIL-STD-202; METHOD 106
- EXPLOSION PROOF PER MIL-STD-202; METHOD 109
- SALT SPRAY PER MIL-STD-202; METHOD 101, CONDITION "B"

The series 1830 is available with 1 pole, 2-12 positions and 2 pole, 2-6 positions, plus 4 pole 2-3 positions. Available in standard solder lug or PC terminals, the Cole Series 1830, with its unique design, renders the switch resistant to water, contaminants, and most solvents.

The 1830 Series is designed for low level current (10 mA) @ (30mV) DC or peak AC, as well as standard ratings.

1830 SERIES

.562" Diameter, 30° Indexing Enclosed Rotary Switches

The full QPL'd MIL switch is commercially available, as are all these configurations:

- 1830 Standard (page 3)
- 1830 Screwdriver Shaft (page 3)
- 1830 Coded (page 4)
- 1830 Spring Return (page 7)
- 1830 Push/Pull (page 5)

1830 SERIES

.562" Diameter, 30° Indexing Enclosed Rotary Switches

ISO 9001:2015 and
AS9100:2016 Rev. D Certified

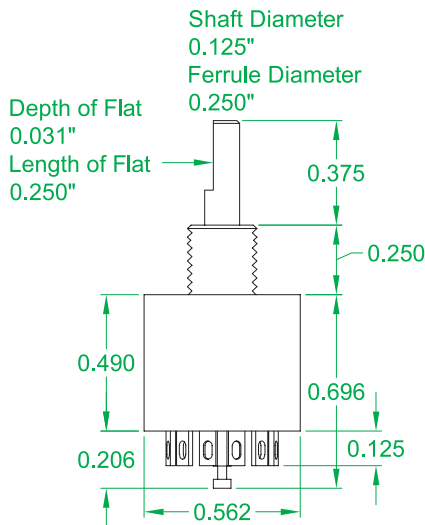

1830 Standard
(See Page 3)

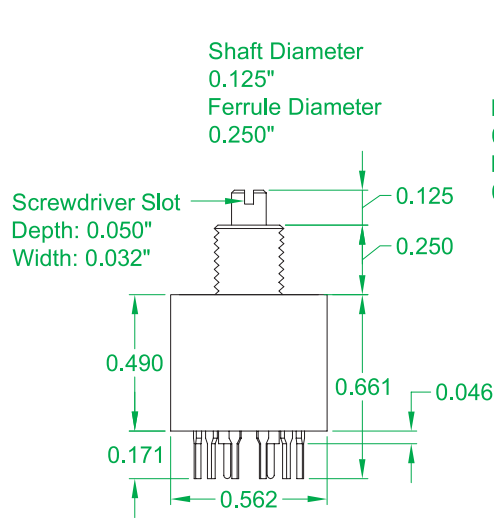

1830 Screwdriver Shaft
(See Page 3)

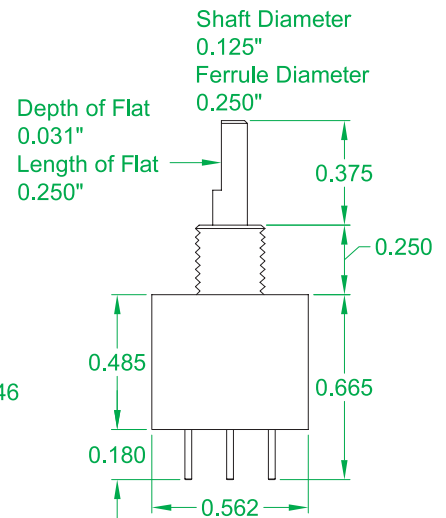

1830 Coded
(See Page 4)

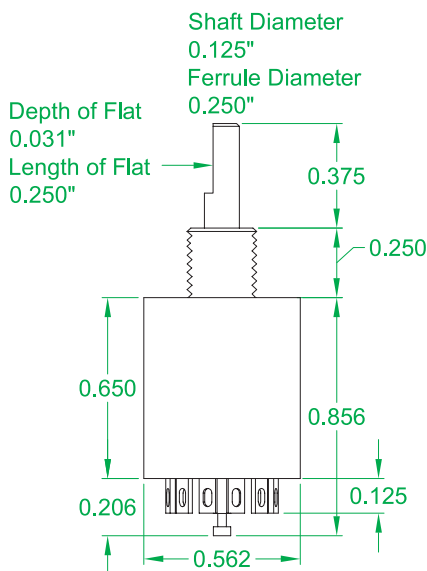

1830 Spring Return
(See Page 7)

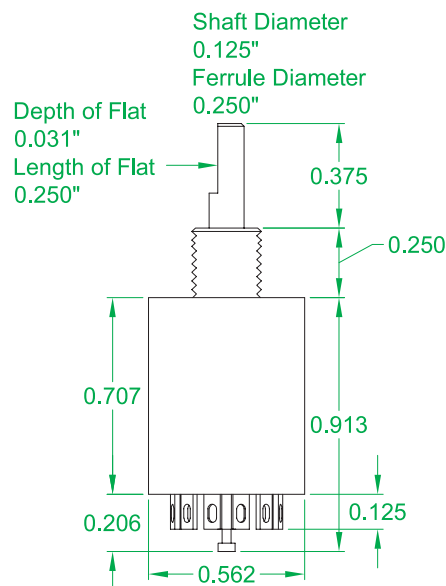

1830 Push/Pull
(See Page 5)

NOTES:

- 1830 Standard – .125 Shaft Diameter, .250 Ferrule Diameter, .562 Body Diameter, (See Page 3).
- 1830 Screwdriver Shaft – .125 Shaft Diameter, .250 Ferrule Diameter, .562 Body Diameter, (See Page 3).
- 1830 Coded – .250 Shaft Diameter, .375 Ferrule Diameter, .562 Body Diameter, (See Page 4).
- 1830 Push/Pull – .125 Shaft Diameter, .250 Ferrule Diameter, .562 Body Diameter, (See Page 5).
- 1830 Spring Return – .125 Shaft Diameter, .250 Ferrule Diameter, .562 Body Diameter, (See Page 7).



COLE
INSTRUMENT CORP.

2650 South Croddy Way
P.O. Box 25063
Santa Ana, CA 92799-5063

Phone: 714.556.3100
Fax: 714.241.9061

Email: sales@cole-switches.com

www.cole-switches.com

©2018 Cole Instrument Corp. All rights reserved. REVISION: J

PAGE
2

1830 SERIES

.562" Diameter, 30° Indexing Enclosed Rotary Switches

ISO 9001:2015 and
AS9100:2016 Rev. D Certified

1830 Standard Series

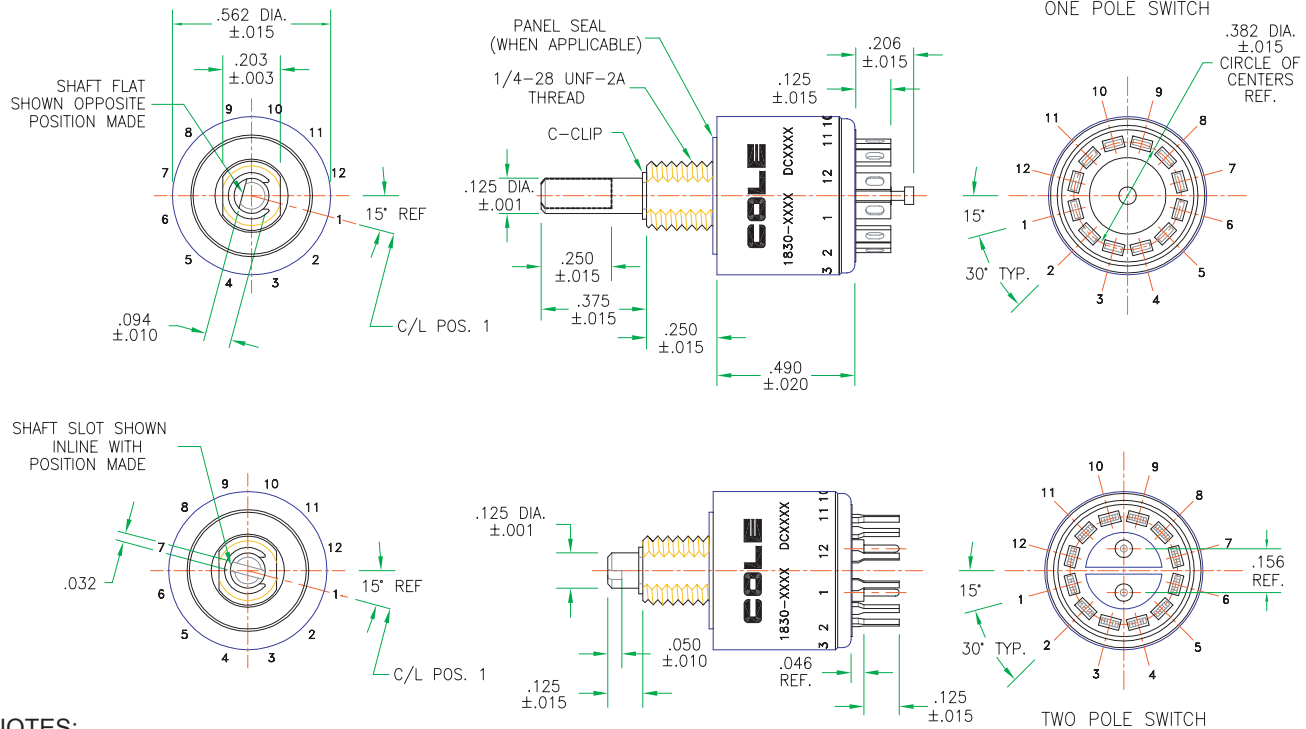

NOTES:

1. Dimensions are in inches.
2. Unless otherwise specified, tolerances are $\pm .005$ and $\pm 3^\circ$ on angles (non-accumulative).
3. Position 1 and terminal 1 coincide.
4. The screw-driver slotted shaft dimensions are indicated; all other remains the same.
The slot in the shaft lines up with the point of contact of pole number one.
5. The standard 1830 is furnished with: 1/8 diameter shaft, solder lug termination, non-shorting contacts, without seals, and continuous rotation (no stops) for full-turn switches.

PART NUMBER ORDERING EXAMPLES

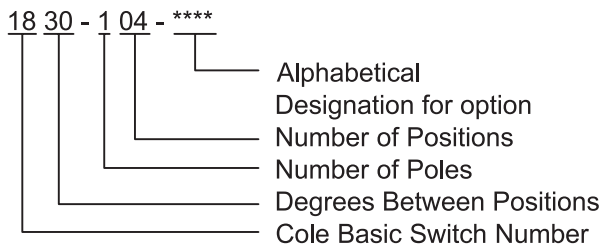

18 30 -1 04 -CPS

Part Number for a 1830, 1/8" diameter shaft, 30° indexing, 1 pole per deck, 4 positions per pole, shorting contacts shaft and panel seals, and PC terminals.

18 30-2 02 -GQ

Part Number for a 1830, 1/4" diameter shaft, 30° indexing, 2 poles per deck, 2 positions per pole, non-shorting contacts, RFI-EMI shielding, and solder lug terminals.

OPTIONS

The following options can be added to the standard switch. When ordering, simply add the letters after the basic part number.

Options listed in alphabetical order only.

A = Adjustable stops.

C = Printed circuit mounting terminals.

F = Fixed stop between the first and last position on the 12 position switch.

G = RFI-EMI shielding.

P = Panel and shaft seals.

Q = 1/4" diameter shaft.

S = Shorting type switch.

SD = Screwdriver Slot.

T = Pre-tinned terminals.

Y = Non-turn washer.



2650 South Croddy Way
P.O. Box 25063
Santa Ana, CA 92799-5063

Phone: 714.556.3100
Fax: 714.241.9061

Email: sales@cole-switches.com

www.cole-switches.com

©2018 Cole Instrument Corp. All rights reserved. REVISION: J

PAGE
3

1830 SERIES

.562" Diameter, 30° Indexing Enclosed Rotary Switches

ISO 9001:2015 and
AS9100:2016 Rev. D Certified

1830 Coded

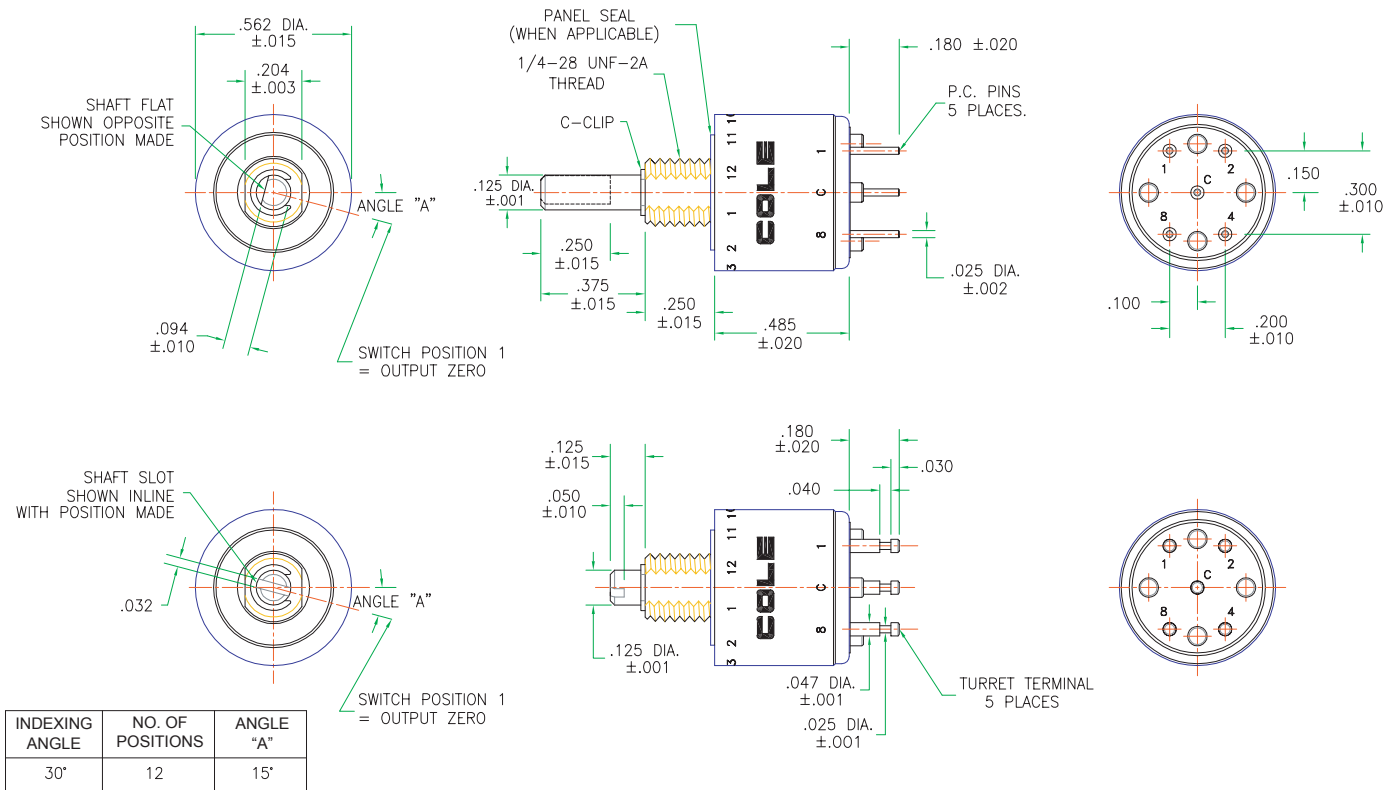

NOTES:

1. Dimensions are in inches.
2. Unless otherwise specified, tolerances are $\pm .005$ and $\pm 3^\circ$ on angles (non-accumulative).
3. Position 1 and terminal 1 coincide.
4. The screw-driver slotted shaft dimensions are indicated; all other remains the same. The slot in the shaft lines up with the point of contact of pole number one.

30° – 12 Positions
BINARY CODED DECIMAL (12 BIT)

COMMON "C" CONNECTED TO TERMINALS	SWITCH POSITION											
	0	1	2	3	4	5	6	7	8	9	10	11
1		•		•		•		•		•		•
2			•		•		•		•		•	
4				•		•		•		•		•
8									•		•	•

ORDERING INFORMATION

For Binary Coded Decimal (12 bit)

Order Number
1830-BCD-12

OPTIONS

The following options can be added to the standard switch. When ordering, simply add the letters after the basic part number.

A = Adjustable stops.

F = Fixed stop between the last and first position of switches.

P = Panel and shaft seals.

SD = Screwdriver slot.

Special Cole P/N to be assigned



COLE
INSTRUMENT CORP.

2650 South Croddy Way
P.O. Box 25063
Santa Ana, CA 92799-5063

Phone: 714.556.3100
Fax: 714.241.9061

Email: sales@cole-switches.com

www.cole-switches.com

©2018 Cole Instrument Corp. All rights reserved. REVISION: J

PAGE
4

1830 SERIES

.562" Diameter, 30° Indexing Enclosed Rotary Switches

ISO 9001:2015 and
AS9100:2016 Rev. D Certified

1830 Pull/Push

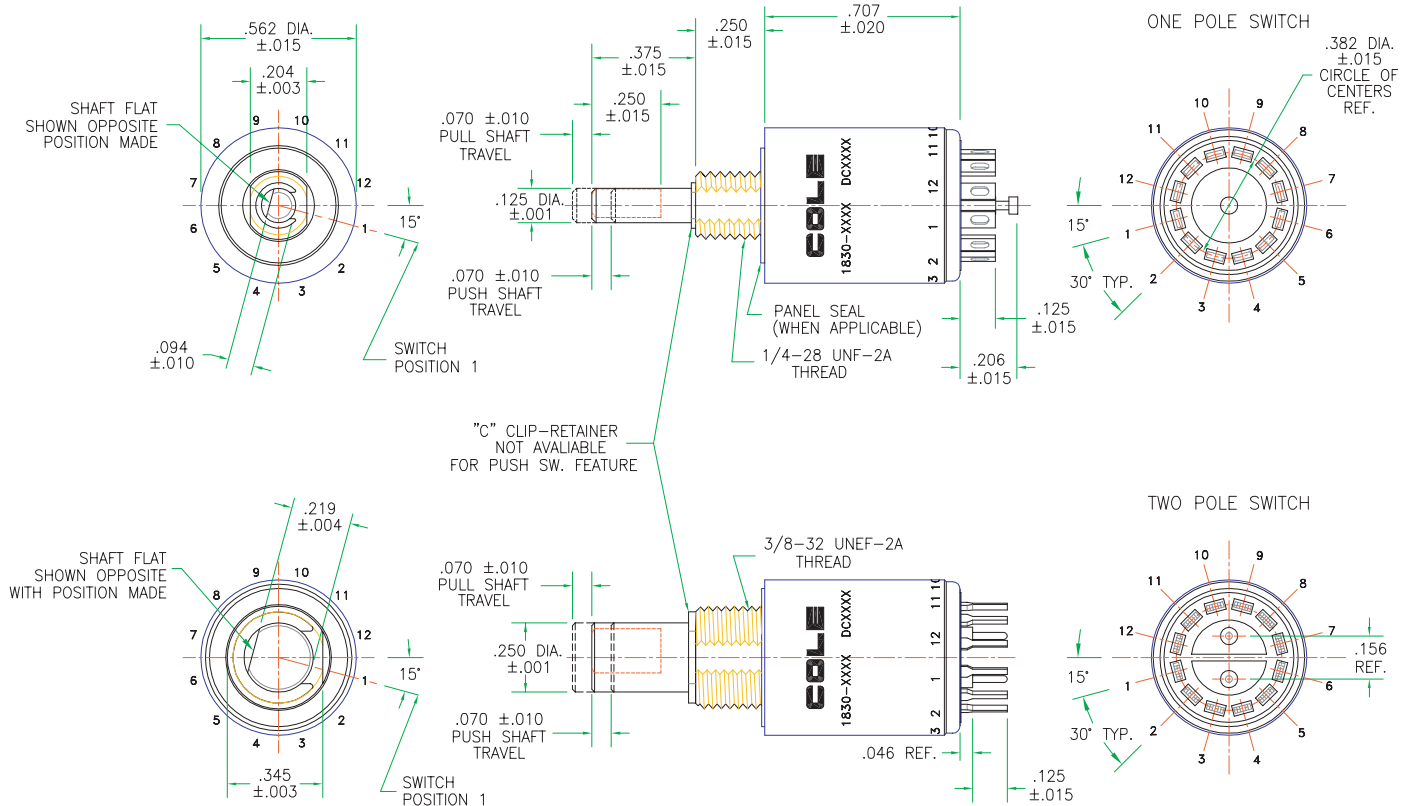

NOTES:

1. Dimensions are in inches.
2. Unless otherwise specified, tolerances are $\pm .005$ and $\pm 3^\circ$ on angles (non-accumulative).
3. Position 1 and terminal 1 coincide.
4. Switches are provided with a full circle of terminals, regardless of number of active position.

ORDERING INFORMATION

Begin by identifying the switch using the COLE part numbering system as shown:

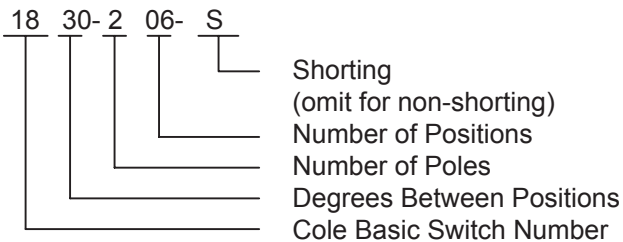

Indicate this is a SPECIAL switch to ensure that no error is made when the order is entered.

Sample part number:

SPECIAL
1830-206-S
STOP1PS2PS3PS4 6STOP

This sample part number orders a Series 1800 standard style switch, 36° indexing, 2 poles, 5 positions per pole shorting, and push-to-turn isolation posts between positions 1-2, 2-3, and 3-4.

Although somewhat long, use of this numbering scheme will prevent error in orders processing. Upon receipt of your order, a special number will be issued unique to this switch. These numbers will not relate to the coding system and will be logged as "special".

The acknowledgment of your order will identify this number. Your specific switch will be the only one identified by this number. Contact Cole for price.



COLE
INSTRUMENT CORP.

2650 South Croddy Way
P.O. Box 25063
Santa Ana, CA 92799-5063

Phone: 714.556.3100
Fax: 714.241.9061

Email: sales@cole-switches.com

www.cole-switches.com

©2018 Cole Instrument Corp. All rights reserved. REVISION: J

PAGE
5

1830 SERIES

.562" Diameter, 30° Indexing Enclosed Rotary Switches

ISO 9001:2015 and
AS9100:2016 Rev. D Certified

1830 Isolated Position Switch Description

A special feature of rotary switches is available known as “isolated position”. This feature allows switch shaft rotation that requires the user to either pull or push the shaft before it will respond to rotational torque. The user identifies the position or positions affected by the isolation mechanism.

Incorporation of the isolated position feature in Cole’s 1830 Series switches will add 0.217 inches to the length.

SPECIFYING POSITIONS

The Cole System for identifying isolation positions lets you perform the selection by inserting isolation posts next to the positions to be isolated. An 1830 Series switch with 30° indexing and continuous rotation is shown below with no isolation position identified in the spaces between the terminals.

12_1_2_3_4_5_6_7_8_9_10_11_12

If you isolate positions 1, 2 and 3, the isolation post insertion points are identified by the letters PL (for actuation by pulling the shaft out), or PS (for actuation by pushing the shaft in) as shown below:

12PL1PL2PL3PL4 5 6 7 8 9 10 11 12

This indicates that you can only get to positions 1, 2 and 3 by pulling on the shaft while all other positions can be achieved with normal rotational torque on the shaft.

If positions 1 and 2 are isolated from all other position but not from each other:

2PS1 2PS3 4 5 6 7 8 9 10 11 12

In this case you need to push on the shaft to get to position 1 from position 12 as well as position 2 from position 3. However, to get from position 1 to position 2 merely requires rotational torque on the shaft.

As a special feature, certain positions on the switch can be isolated in unidirectional mode. That means that the positions can be achieved with normal rotational torque on the shaft, but requires a push or pull action to get to the next position (Ramp-In). Conversely, reaching the isolated position with a push or pull action on the shaft but requiring normal rotational torque (Ramp-out) for the next position, is also available. Please consult the factory for special features.

SPECIFYING STOPS

Stops must be incorporated when a switch has multiple poles or specifies less than the numbers of positions available. If a switch with 30° indexing is specified as an 8 position switch with position 1 isolated with push actuation required, the designation would be:

STOP1PS2 3 4 5 6 7 8STOP

Since the stop mechanism is inserted between positions 12 and 1, the isolation post is only required between positions 1 and 2. The stop mechanism inserted between terminals 8 and 9 serves to limit the switch to 8 positions.

When stop and isolation mechanism are used in multipole switches, all poles are slaved to the first pole in the case of a 2 pole, 12 position switch with 30° indexing, isolating position 1 will automatically isolate position 7. (Refer to the standard switch schematics for 30° indexing switches, page No. 3



COLE
INSTRUMENT CORP.

2650 South Croddy Way
P.O. Box 25063
Santa Ana, CA 92799-5063

Phone: 714.556.3100
Fax: 714.241.9061

Email: sales@cole-switches.com

www.cole-switches.com

©2018 Cole Instrument Corp. All rights reserved. REVISION: J

PAGE
6

1830 SERIES

.562" Diameter, 30° Indexing Enclosed Rotary Switches

ISO 9001:2015 and
AS9100:2016 Rev. D Certified

1830 Spring Return

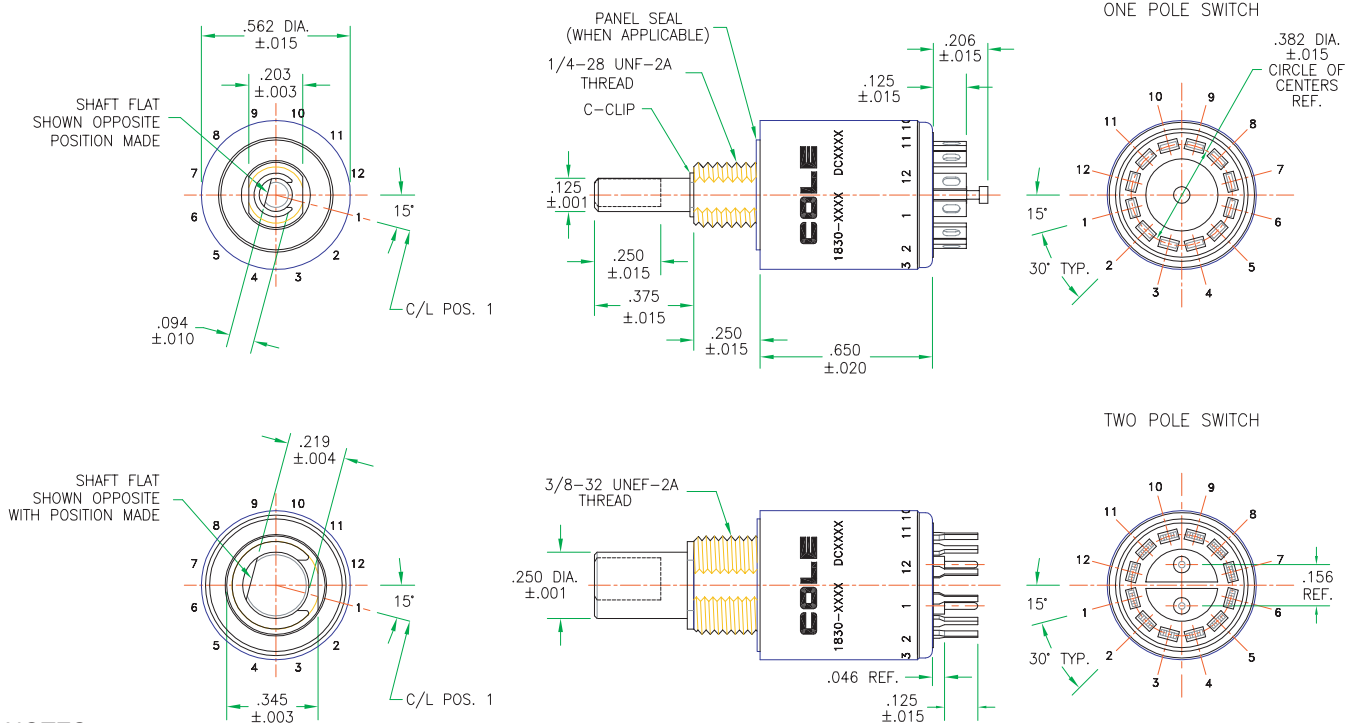

NOTES:

1. Dimensions are in inches.
2. Unless otherwise specified, tolerances are $\pm .005$ and $\pm 3^\circ$ on angles (non-accumulative).
3. Position 1 and terminal 1 coincide.
4. Switches are provided with a full circle of terminals, regardless of number of active position.
5. Spring return life-cycle is 15,000 momentary cycles for the 1830 form factor.

DESCRIPTION:

A spring return rotary switch requires that manual torque be maintained at the desired switch position. Releasing the force allows the spring to return the contact to a normal, or detent positions. Arrows in the CONFIGURATIONS AND RESTRICTIONS TABLE indicate the direction the spring will return the contact so it assumes a normal detent position, the "D" designates a normal detent position.

ORDERING INFORMATION

Create the part number using this example:

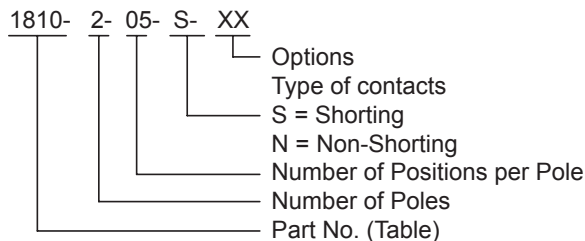

This sample part number orders a 1830 Series switch with 30° indexing, momentary terminal 5 returning to terminal 4 (10 to 9 is slaved), 2 poles, 5 positions per pole, shorting contacts, with options available as shown in the table.

OPTIONS

The following options can be added to the standard switch. When ordering, simply add the letters after the basic per number. Options listed in alphabetical order only.

- G = RFI-EMI shielding.
- P = Panel and shaft seals.
- SD = Screwdriver slot.
- W = Washable.
- Y = Non-turn washer.
- S = Shorting
- C = PC Terminals
- Q = 1/4" Dia. shaft
- T = Pre-tinned terminals



COLE
INSTRUMENT CORP.

2650 South Croddy Way
P.O. Box 25063
Santa Ana, CA 92799-5063

Phone: 714.556.3100
Fax: 714.241.9061

Email: sales@cole-switches.com

www.cole-switches.com

©2018 Cole Instrument Corp. All rights reserved. REVISION: J

1830 SERIES

.562" Diameter, 30° Indexing Enclosed Rotary Switches

ISO 9001:2015 and
AS9100:2016 Rev. D Certified

1830 Spring Return Rotary Switch Description

A rotary switch with a spring return mechanism allows certain selected positions to have momentary action wherein they can be maintained only with positive force on the shaft. Releasing the shaft will return the switch to its previous position. This feature is available in the COLE SERIES 1800, 1830, and 3600 switches.

Addition of this mechanism to the SERIES 1830 switch adds 0.217 inches to its length; all other dimensions remain unchanged.

The spring return feature in the SERIES 1830 switch is available only with 30° angle of throw as a standard.

Custom requirements can be accommodated by contacting the factory.

CONFIGURATIONS AND RESTRICTIONS TABLE

INDEXING	Part No.	Switch Action	No. of poles	Position Per Pole	Terminal Opposite to Flat
30° SPRING RETURN	1801	1->2	1 or 2	2	2
	1802	1<-2	1 or 2	2	1
	1803	1->2D3	1 or 2	3	2
	1804	1D2<-3	1 or 2	3	1
	1805	1->2<-3	1 or 2	3	2
	1806	1->2D3D4	1 or 2	4	2
	1807	1D2D3<-4	1 or 2	4	1
	1808	1->2D3<-4	1 or 2	4	2
	1809	1->2D3D4D5	1 or 2	5	2
	1810	1D2D3D4<-5	1 or 2	5	1
	1811	1->2D3D4<-5	1 or 2	5	2
	1812	1->2D3D4D5D6	1 or 2	6	2
	1813	1D2D3D4D5>-6	1 or 2	6	1
	1814	1->2D3D4D5<-6	1 or 2	6	2

THE MAXIMUM NUMBER OF POLES PER SWITCH IS 2.

-> DIRECTION OF SPRING RETURN <-

FOR DIFFERENT REQUIREMENTS PLEASE CONTACT THE FACTORY.



COLE
INSTRUMENT CORP.

2650 South Croddy Way
P.O. Box 25063
Santa Ana, CA 92799-5063

Phone: 714.556.3100
Fax: 714.241.9061

Email: sales@cole-switches.com

www.cole-switches.com

©2018 Cole Instrument Corp. All rights reserved. REVISION: J

PAGE
8

1830 SERIES

.562" Diameter, 30° Indexing Enclosed Rotary Switches

ISO 9001:2015 and
AS9100:2016 Rev. D Certified

Configurations and Restrictions Table

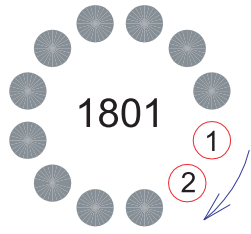
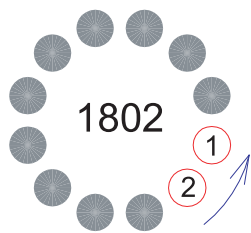
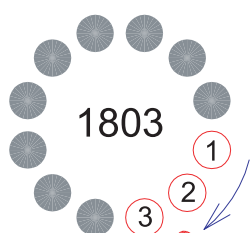
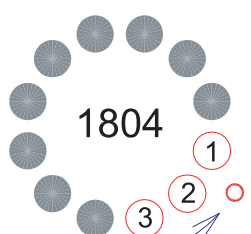
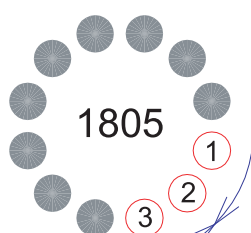
Indexing	Part No.	Switch Action	Switch Action Description	No. of Poles	Position per Pole	Lowest Non-Momentary Position
30°	1801		1 → 2	1 or 2	2	2
30°	1802		1 ← 2	1 or 2	2	1
30°	1803		1 → 2D3	1 or 2	3	2
30°	1804		1D2 ← 3	1 or 2	3	1
30°	1805		1 → 2 ← 3	1 or 2	3	2



COLE
INSTRUMENT CORP.

2650 South Croddy Way
P.O. Box 25063
Santa Ana, CA 92799-5063

Phone: 714.556.3100
Fax: 714.241.9061

Email: sales@cole-switches.com

www.cole-switches.com

©2018 Cole Instrument Corp. All rights reserved. REVISION: J

1830 SERIES

.562" Diameter, 30° Indexing Enclosed Rotary Switches

ISO 9001:2015 and
AS9100:2016 Rev. D Certified

Configurations and Restrictions Table

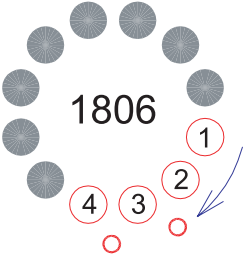
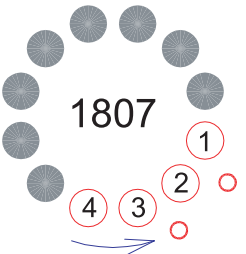
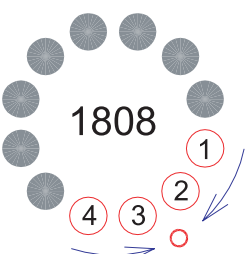
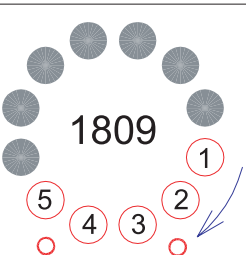
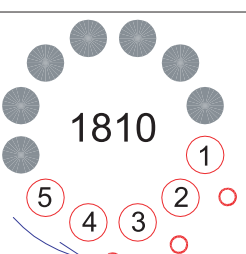
Indexing	Part No.	Switch Action	Switch Action Description	No. of Poles	Position per Pole	Lowest Non-Momentary Position
30°	1806		1→2D3D4	1 or 2	4	2
30°	1807		1D2D3←4	1 or 2	4	1
30°	1808		1→2D3←4	1 or 2	4	2
30°	1809		1→2D3D4D5	1 or 2	5	2
30°	1810		1D2D3D4←5	1 or 2	5	1



COLE
INSTRUMENT CORP.

2650 South Croddy Way
P.O. Box 25063
Santa Ana, CA 92799-5063

Phone: 714.556.3100
Fax: 714.241.9061

Email: sales@cole-switches.com

www.cole-switches.com

©2018 Cole Instrument Corp. All rights reserved. REVISION: J

1830 SERIES

.562" Diameter, 30° Indexing Enclosed Rotary Switches

ISO 9001:2015 and
AS9100:2016 Rev. D Certified

Configurations and Restrictions Table

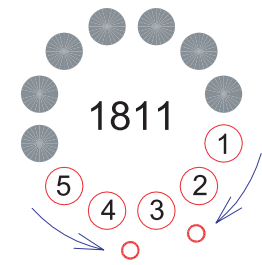
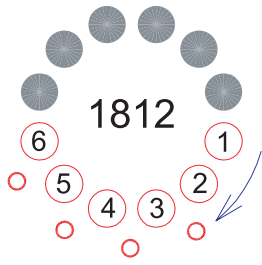
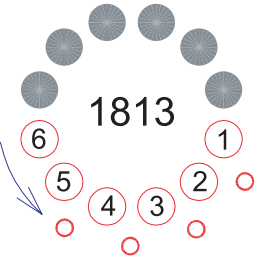
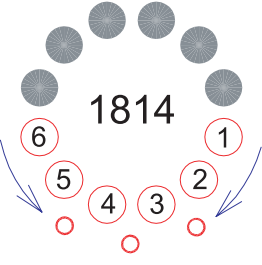
Indexing	Part No.	Switch Action	Switch Action Description	No. of Poles	Position per Pole	Lowest Non-Momentary Position
30°	1811		1→2D3D4←5	1 or 2	5	2
30°	1812		1→2D3D4D5D6	1 or 2	6	2
30°	1813		1D2D3D4D5←6	1 or 2	6	1
30°	1814		1→2D3D4D5←6	1 or 2	6	2



COLE
INSTRUMENT CORP.

2650 South Croddy Way
P.O. Box 25063
Santa Ana, CA 92799-5063

Phone: 714.556.3100
Fax: 714.241.9061

Email: sales@cole-switches.com

www.cole-switches.com

©2018 Cole Instrument Corp. All rights reserved. REVISION: J

PAGE
11

1830 SERIES

.562" Diameter, 30° Indexing Enclosed Rotary Switches

ISO 9001:2015 and
AS9100:2016 Rev. D Certified

1830 Series Typical Features

REAR VIEW FOR SOLDER LUG & PC. TERMINAL

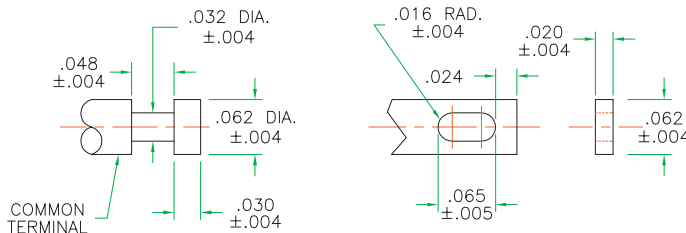
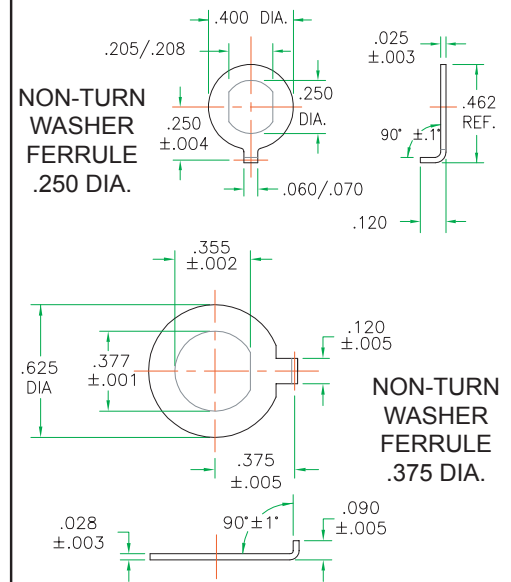
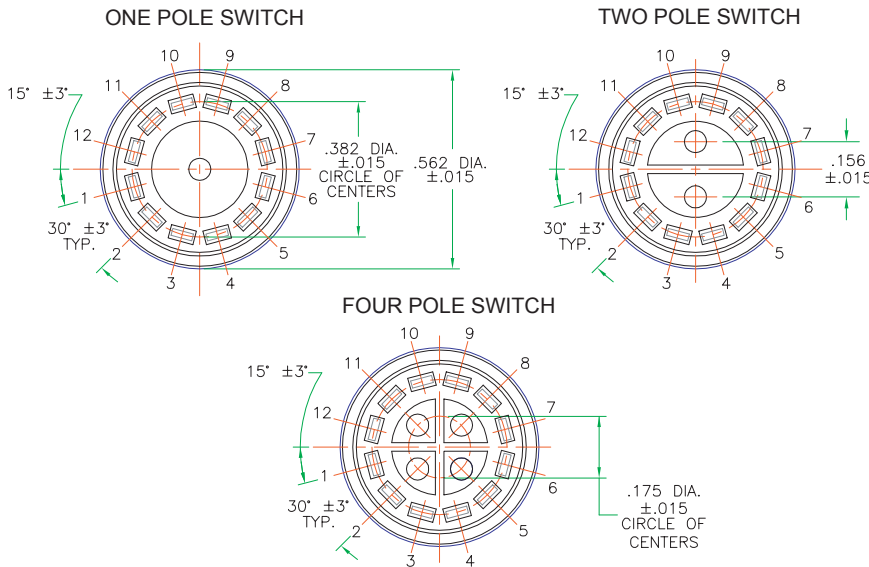

SOLDER-LUG TERMINAL DETAIL

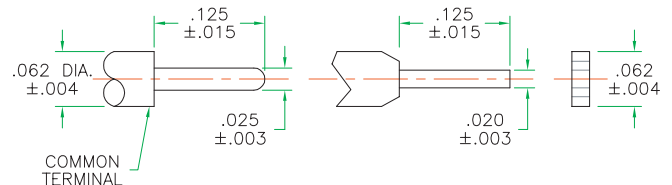

PRINTED CIRCUIT TERMINAL DETAIL

SCHEMATIC DIAGRAMS (VIEWED FROM SHAFT END AND SHOWN IN POSITION #1)

30° ANGLE OF THROW

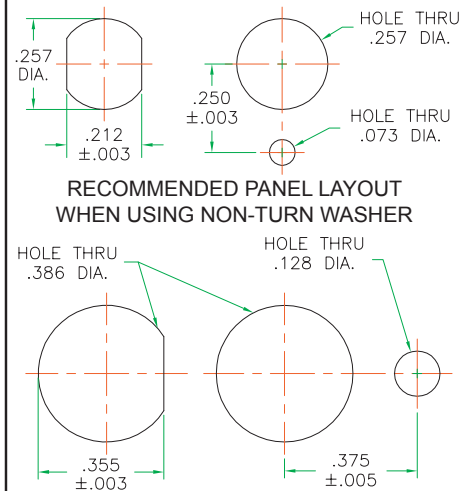
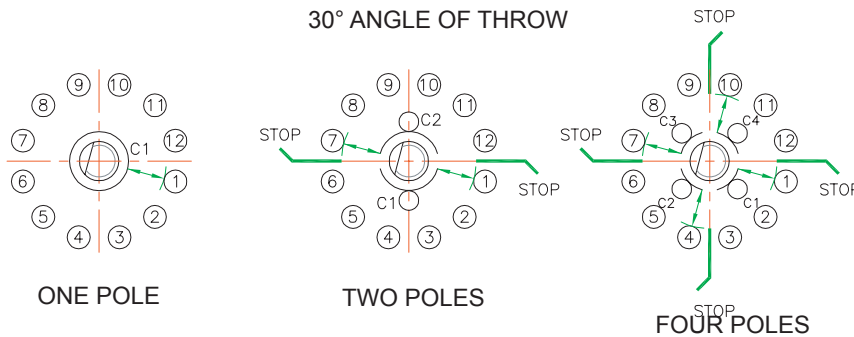

RECOMMENDED PANEL LAYOUT
WHEN USING NON-TURN WASHER

NOTES:

1. Dimensions are in inches.
2. Unless otherwise specified, tolerances are ± 0.010 and $\pm 3^\circ$ on angles (Non-accumulative).
3. Position 1 and Terminal 1 coincide.
4. Dimension shown are typical for all angles of throw, unless otherwise specified.



COLE
INSTRUMENT CORP.

2650 South Croddy Way
P.O. Box 25063
Santa Ana, CA 92799-5063

Phone: 714.556.3100
Fax: 714.241.9061

Email: sales@cole-switches.com

www.cole-switches.com

©2018 Cole Instrument Corp. All rights reserved. REVISION: J

PAGE
12

1830 SERIES

.562" Diameter, 30° Indexing Enclosed Rotary Switches

ISO 9001:2015 and
AS9100:2016 Rev. D Certified

Series 1830 Technical Data

Specification	Unit	Value	Note:
Military Specifications		MIL-DTL-3786	
Continuous (Non-Switching) Current Carrying Capacity	Amps	6	at 28 VDC, with max. contact temperature rise of 20°C
Switching Current Capacity at 28 VDC resistive	Amps	0.200	at Atmospheric pressure with 85°C and at reduced Barometric pressure with 25°C
Switching Current Capacity at 115 VAC resistive	Amps	0.150	
Switching Current Capacity at 28 VDC inductive (2.8 H.)	Amps	0.030	
Switching Current Capacity at 28 VDC Lamp Load	Amps	0.100	
Low Level max. capacity	mA	10	at 30 millivolts DC max.
Dielectric Strength, min.	VRMS	450	
Contact resistance, max. (initial)	milliohms (mΩ)	50	
Contact resistance, max. (after life)	milliohms (mΩ)	100	
Insulation resistance, min. (initial)	megaohms (MΩ)	50,000	at 100 VDC
Insulation resistance, min. (after life)	megaohms (MΩ)	25,000	at 100 VDC
Switching Life	cycles	25,000	at rated loads, sea-level, 25°C, 68% relative humidity
Mechanical Life	cycles	25,000	
Spring Return Life	cycles	15,000	for momentary cycles
Rotational Torque, min.	inch ounces	8	
Rotational Torque, max.	inch ounces	24	
Stop Strength, max.	inch pounds	7	
Mounting Ferrule Strength	inch pounds	15	
Withstanding Shaft Push Force	pounds	100	
Weight	grams	13	
Molded Parts		thermoplastic	
Contact Surfaces		Gold plated	
Altitude	feet	70,000	typical pressure at 70,000 feet: 0.64 psi
Temperature, min.	degrees Celsius	-65	
Temperature, max.	degrees Celsius	85	
Vibration Tested		Meets	Per MIL-DTL-3786, MIL-STD-202, Method 204, test condition "B", vibration grade 3
Impact Shock, Medium		Meets	MIL-STD 202; Method 213
Impact Shock, High		Meets	at 100g, MIL-STD 202, Method 207
Moisture Resistant		Meets	MIL-STD 202; Method 106
Salt Spray Resistant		Meets	MIL-STD 202, Method 101, Condition "B"
Explosion Proof		Meets	MIL-STD 202, Method 109
Immersion		Meets	3 feet water, MIL-STD-202, method 104, test condition "C"
EMI/RFI		Meets	MIL-DTL-3786, 2 ohms Shaft to ground max.



COLE
INSTRUMENT CORP.

2650 South Croddy Way
P.O. Box 25063
Santa Ana, CA 92799-5063

Phone: 714.556.3100
Fax: 714.241.9061

Email: sales@cole-switches.com

www.cole-switches.com

©2018 Cole Instrument Corp. All rights reserved. REVISION: J

PAGE
13